

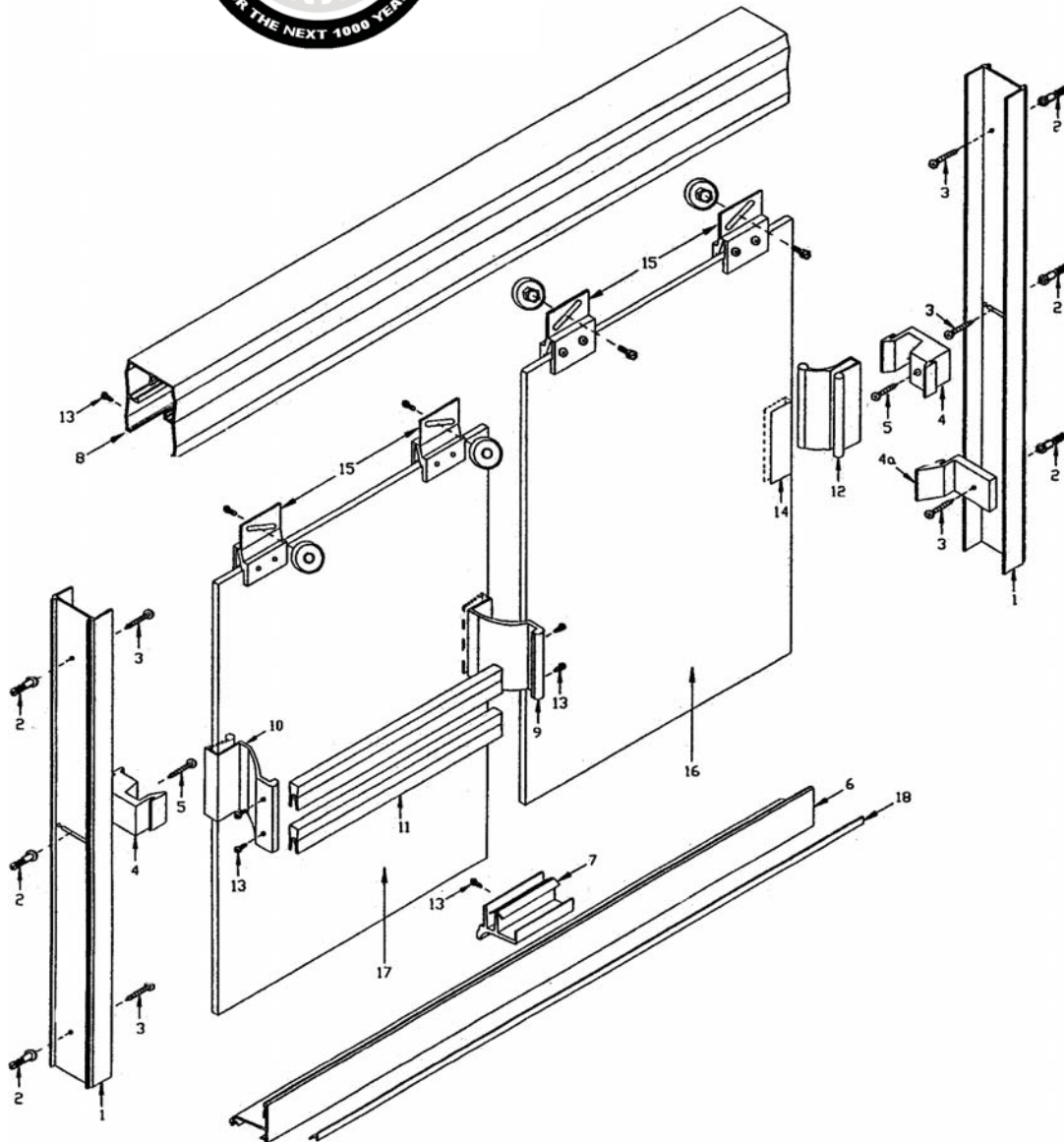

TUB / SHOWER ENCLOSURE  
MTE / MSE 1400

- For assembly you will need:
1. Phillips Screwdriver
  2. 1/4" Box End Wrench
  3. Hack Saw
  4. Silicone
  5. 3/16" Carbide Drill Bit (for tile walls)
  6. #31 Drill Bit
  7. Level



When Ordering Repair Parts, Please Give The Following Information:

1. Model Number
2. Part Number
3. Part Description
4. Color

Description	Qty.	Part #	Picture
1. Wall Jamb	2	MTE1203	
2. Wall Anchors	6	ANCHOR	
3. #8 x 1 1/2 SMS Screws	6	MBG812-SMA	
4. Door Bumper	2	MV-925	
4a. Bottom Bumper	1	MV-926	
5. 6-32 x 1/2" MS Screws #6 x 1/2 TC	2	MBG612-TC	
6. Bottom Sill (with MV-918)	1	MTE1522	
7. Center Guide - 3"	1	MBG-530-3	
8. Header	1	MTE1201	
9. Towel Bar Bracket	1	MTE1206	
10. Towel Bar Bracket With Pull	1	MTE1206P	
11. Towel Bars	2	MTE1205	
12. Inside Door Pull	1	MTE1207	
13. #6 x 3/8 SMS Screws	7	MBG638-SM	
14. Handle Vinyl	3	MV-916	
15. Roller Bracket Assembly	4	MTE1208-F	
16. Inside Glass Panel	1	Inside Slider	
17. Outside Glass Panel	1	Outside Slider	
18. Door Guide Vinyl (with MTE1522)	1	MV-918	
19. Header Retainer Clips	2	MV-952	

# Assembly and Installation Instructions



**Note:** Apply a bead of silicone (GE1200) into the open channel of roller bracket before attaching to glass. To assemble roller bracket (15) to glass, tighten screws until surface of roller bracket is depressed 1/32" (29 inchpounds of torque). Allow to cure for 24 hours before hanging sliders.

**Figure 1**

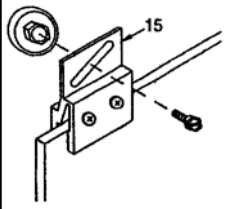

1. Set wall jamba (1) in place on walls, centering bottom of jamba on rim of tub. Hold plumb and mark walls for screw holes.
2. Remove and drill 3/16" diameter holes in walls (use carbide tipped drill bit for tile walls). Insert plastic wall anchors (2) into holes. Silicone where wall meets the rim of the tub to seal the bottom of jamba. Set jamba in place and secure to the wall with #8 x 1 1/2 screws (3). Secure Bottom Bumper (4a) on showerhead inside side with the bottom wall jamba screw.

**Figure 2**

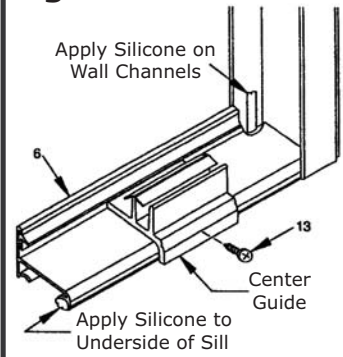

3. Cut sill (6) to fit opening between jamba. Run a bead of silicone full length to the underside of sill (See Figure 2) and apply silicone to inside of jamba where jamba meets tub. On inside of jamba, run a 1/4" bead of silicone 1 1/4" up the outside leg of each wall jamba (See Figure 2). Set sill in place and press firmly to rim of tub. Wipe off any excess silicone before curing. Use tape to hold in place until silicone has set.

4. Cut header (8) 1/32" to 1/16" less than opening width and set in place.

5. To set slider glass in place, hold inside slider inside of tub or shower pan, insert rollers up into header and lower into place. The inside will close against the wall jamba on the showerhead side. Next, insert lower end of outside slider in front of inside slider by pushing lower ends far enough in to allow clearance on inside edge of tub or pan. Avoid roller bracket to roller bracket contact while lifting panel into place. The outside slider will close against the jamba opposite the showerhead.

6. Place center guide (7) to center position on sill (See Figure 2). Make sure the center guide is hooked into the slot position on the sill, then drill a hole using a #31 drill bit and fasten center guide to sill with the #6 x 3/8" screw (13) provided.

7. Close panels and adjust to align the vertical edge of panels with jamba. Using a 1/4" box-end wrench, loosen the screws on the rollers, but don't remove completely. When screws are loose, adjust panel by sliding the screw in the slot. Note: When screws are loose be sure to support panel so it does not fall and break. Adjust inside sliders as low as possible to reduce the gap between bottom of slider and sill, taking care that the glass does not drag on the track or center guide.

**Figure 3** Outside Door Panel

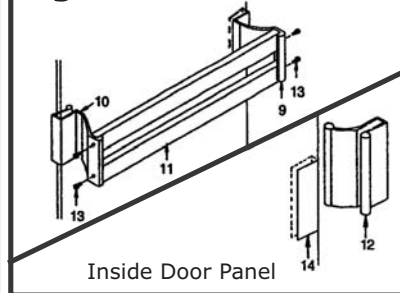

8. Set handle vinyl channel (14) in place over edge of outside glass panel (17) with bottom of vinyl in line with bottom of bumper. Tap towel bar brackets (9 & 10) in place. Bracket with pull should be to jamb side of slider opposite shower head. Assemble towel bars (11) to brackets using #6 x 3/8" SMS screws (13).

9. Set handle vinyl (14) in place over edge of inside glass panel (16) with bottom of vinyl in line with bottom of bumper on edge facing the wall jamba (1). Tap inside door pull (12) in place. **NOTE: Large Portion of Pull to Inside of Slider.** This panel should be at the showerhead / Inside side.

10. Center hole in jamb is slotted to allow adjusting of jamb to compensate for bowed glass. After installing hardware, roll both panels into jamb on one side. If edge of glass hits on edge of jamb, loosen center screw and adjust jamb accordingly. Repeat on opposite side. From inside of unit, drill #31 holes through header and into wall jamba. Secure header to wall jamba with two #6 x 3/8" SMS screws (13).

11. Secure bumpers (4) in place with a 6-32 x 1/2" screw (5). **NOTE:** Glass panels close into the recessed portion of the bumpers. The recess is toward the inside of the tub on the showerhead jamb, and toward the outside on the other jamb.

12. Silicone inside of shower where jamba meet walls and sill meets rim of tub.

**Figure 4**

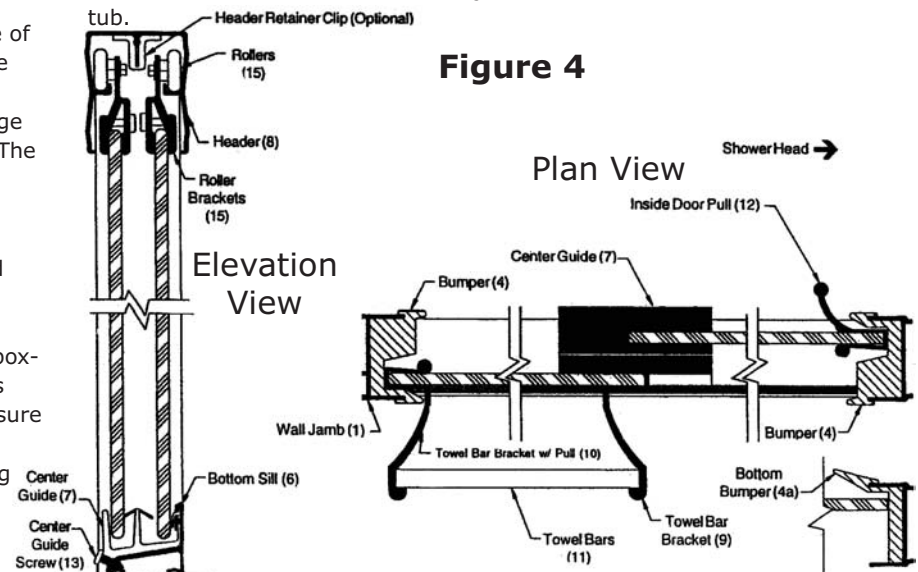

*For the next thousand years.*